

# Gyru-Star 6-150MAX



## Carriers

20 - 30 ton Excavators  
 44000 - 66000 lbs Excavators  
 10 - 15 ton loader Lift Capacity  
 22000 - 33000 lbs Loader Lift Capacity

## Weight

1450 kg  
 3200 lbs

## Capacity

1.60 m<sup>3</sup>  
 1.70 yd<sup>3</sup>

## Flow

150 l/m  
 42 gpm

## Pressure

200 bar  
 2900 PSI

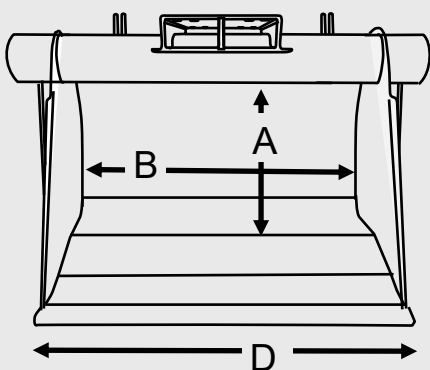

## Screening Area

615 x 1500 mm    24 x 59 inch

## Dimensions

**A** 1030 mm 40 inch    **B** 1500 mm 59 inch

**C** 900 mm 35 inch    **D** 1870 mm 74 inch

**E** 1580 mm 62 inch    **F** 1300 mm 51 inch

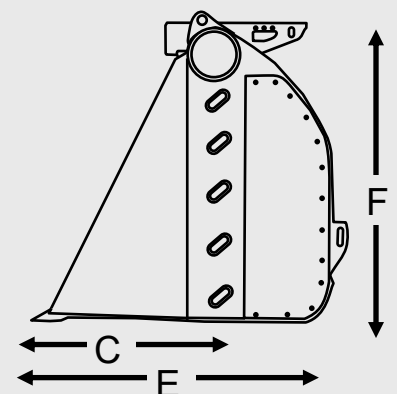

**True compact screening**

**Low maintenance bucket**

**Poly stars which screen without crushing**

**Large screening area to maximise output**

**Non-stick Floor as standard**

***Fast Efficient Screening Systems***