

# Gyru-Star 4-150MAX



## Carriers

13 - 18 ton Excavators  
 28600 - 39700 lbs Excavators  
 6 - 8 ton loader Lift Capacity  
 13200 - 17600 lbs Loader Lift Capacity

## Weight

980 kg  
 2160 lbs

## Capacity

0.80 m<sup>3</sup>  
 1.05 yd<sup>3</sup>

## Flow

90 l/m  
 24 gpm

## Pressure

200 bar  
 2900 PSI

## Screening Area

615 x 1500 mm    24 x 59 inch

## Dimensions

**A** 615 mm 24 inch    **B** 1500 mm 59 inch  
**C** 570 mm 22 inch    **D** 1870 mm 74 inch  
**E** 820 mm 32 inch    **F** 880 mm 35 inch

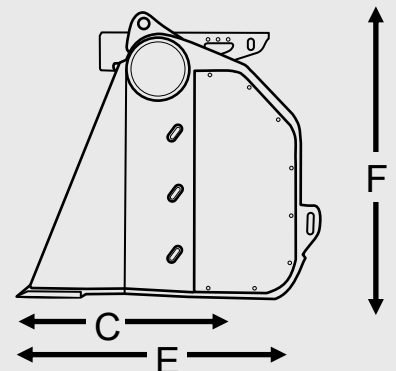
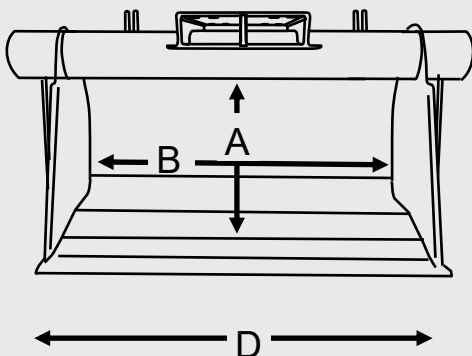

**True compact screening**

**Low maintenance bucket**

**Poly stars which screen without crushing**

**Large screening area to maximise output**

**Non-stick Stainless Steel Floor as standard**

**Fast Efficient Screening Systems**