

Gyru-Star 4-120MAX



Carriers

10 - 13 ton Excavators
 22000 - 28600 lbs Excavators
 6 - 8 ton loader Lift Capacity
 13200 - 17600 lbs Loader Lift Capacity

Weight

740 kg
 1630 lbs

Capacity

0.60 m³
 0.79 yd³

Flow

90 l/m
 24 gpm

Pressure

200 bar
 2900 PSI

Screening Area

615 x 1200 mm 24 x 47 inch

Dimensions

A 615 mm 24 inch **B** 1200 mm 47 inch
C 570 mm 22 inch **D** 1550 mm 61 inch
E 820 mm 32 inch **F** 880 mm 35 inch

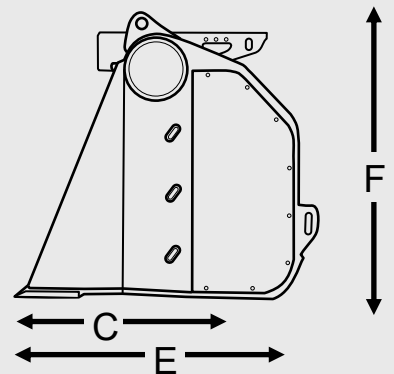
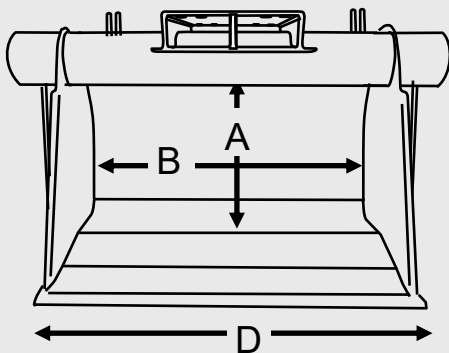

True compact screening

Low maintenance bucket

Poly stars which screen without crushing

Large screening area to maximise output

Non-stick Stainless Steel Floor as standard

Fast Efficient Screening Systems