

Gyru-Star 3-120L



Carriers

1 - 3 Ton Loader Lift Capacity

2200 - 6600 lbs Loader Lift Capacity

Weight

390 kg

890 lbs

Capacity

0.26 m³

0.34 yd³

Flow

65 l/m

17 gpm

Pressure

200 bar

2900 PSI

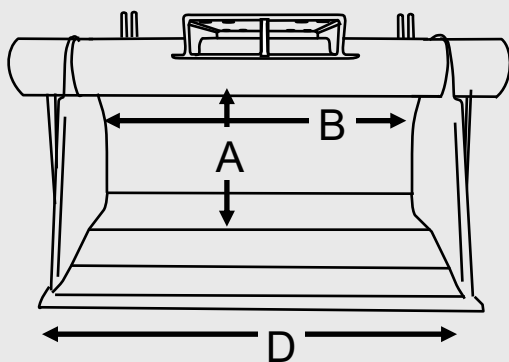

Screening Area

430 x 1200 mm 17 x 47 inch

Dimensions

A 430 mm 17 inch **B** 1200 mm 47 inch

C 500 mm 20 inch **D** 1410 mm 55 inch

E 760 mm 30 inch **F** 640 mm 25 inch

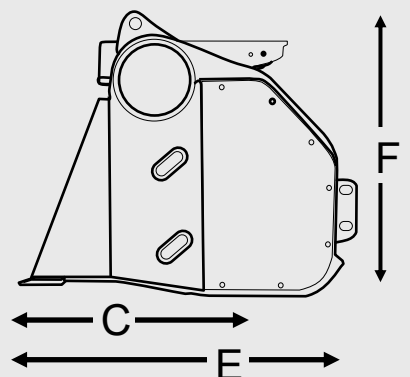

True compact screening

Low maintenance bucket

Poly stars which screen without crushing

Large screening area to maximise output

Non-stick Stainless Steel Floor as standard

Fast efficient screening systems