

HORSE ARENA HARROW

<http://tiny.cc/horsearenaharrow>

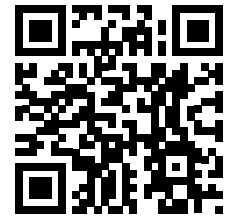

FEATURES & BENEFITS

- Multi-function surface processing
- A professional harrow that makes it easy to keep the horse arena in top condition
- Can be adjusted for several kinds of riding surfaces
- Once the adjustments have been done the harrow is very easy to use
- Support wheels: the harrow can be lifted off the ground and towed to desired place

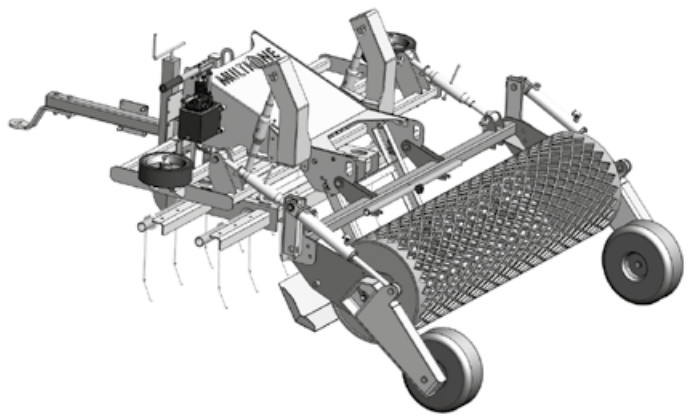

The horse arena harrow is designed to smooth and level sandy or mixed media horse riding surfaces. The harrow features multiple processes, beginning with the three sets of spring tines to break up the surface, a leveler to smooth and level the surface, and the compacting and spreader auger roller assembly that finishes the surface. The harrow also has side wheels that enable working along walls with no damage. Easily made adjustments enable weight and balance adjustments between the spring tines and roller/spreader assembly. Height adjustments to enhance processing difficult soils are made quickly and easily.

Note: the loader must be equipped with the trailer coupling.

Model	Width	Working Depth	Weight	Code
160	160 cm (63 in)	0 - 9 cm (0 - 3.5 in)	218 kg (480 lbs)	C891231

Compatibility	1.1	2.3	4.2	5.2	5.3	6.3	7.2	8.4	8.5	11.6	11.9	EZ5	EZ7 EZ8
		Very compatible						Compatible			Not compatible		

