

# PALLET FORK WITH SIDE SHIFT

<http://tiny.cc/palletforkwithsideshift>



## FEATURES & BENEFITS

- Safely controlled side shift from the driver's position
- Designed to work in tight areas or along narrow aisles
- Different sizes of forks available
- Back stop as standard

Hydraulically side shifting the forks enables easier and safer handling and loading of a wide variety of pallet sizes.

The forks can be moved to the left or to the right, making it possible to shift the load to the side of the machine - closer to a wall for example. This function can be operated from the driver's seat. The fork width is manually adjustable to adapt to different pallets size.

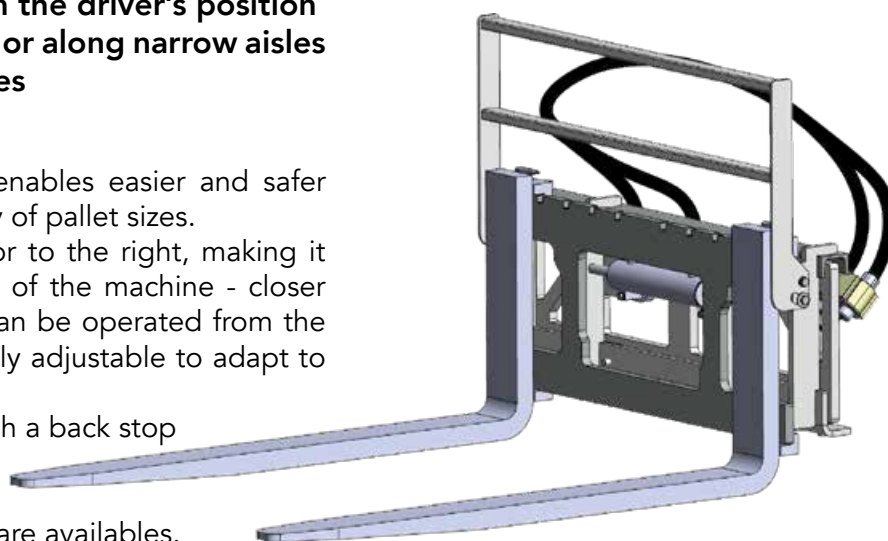
Pallet fork is equipped as standard with a back stop which enables handling of larger loads and protects the driver from falling objects. Different sizes of forks are available.



Model	Forks Length	Lifting Capacity <sup>3</sup>	Side Shift	Weight	Code
Frame (without forks) <sup>1</sup>	/	/	8,5 cm (3.4 in) to the left 8,5 cm (3.4 in) to the right	96 kg (212 lbs)	<b>C890316</b>
90 (forks pair) <sup>2</sup>	90 cm (35.4 in)	1000 kg (2204 lbs)		54 kg (119 lbs)	<b>C890331</b>
110 (forks pair) <sup>2</sup>	110 cm (43.3 in)	1200 kg (2646 lbs)		68 kg (150 lbs)	<b>C890332</b>
120 (forks pair) <sup>2</sup>	120 cm (47.3 in)	2000 kg (4408 lbs)		104 kg (230 lbs)	<b>C890333</b>

(<sup>1</sup>) C890331 or C890332 or C890333 required - (<sup>2</sup>) C890316 required - (<sup>3</sup>) verify the lifting capacity of the machine

Compatibility	1.1	2.3	4.2	5.2	5.3	6.3	7.2	8.4	8.5	11.6	11.9	EZ5	EZ7 EZ8
<b>Model</b>													
90													
110													
120													

Very compatible

Compatible

Not compatible